

REV	DESCRIPTION	BY	DATE	MODEL: 75-16	UNLESS OTHERWISE SPECIFIED TOLERANCES ON DIMENSIONS IN INCHES	THIS DRAWING IS THE PROPERTY OF CAMPBELL INTERNATIONAL, AND MAY NOT BE REPRODUCED FOR ANY PURPOSE WITHOUT WRITTEN CONSENT OF THE COMPANY.	FISH OVEN & EQUIPMENT, INC. WAUCONDA, IL 60084	DWG. # 75-16	REV.
				STYLE:	DECIMALS .XXX ± .030 .XX ± .060				
				ASSEMBLY	FRACTIONAL ± 1/16		TITLE: 75-16 GAS OVEN	DRN BY M.S.	DATE 05/13/04
				NO. REQ'D				CR'D BY	DATE
					MAT'L:				

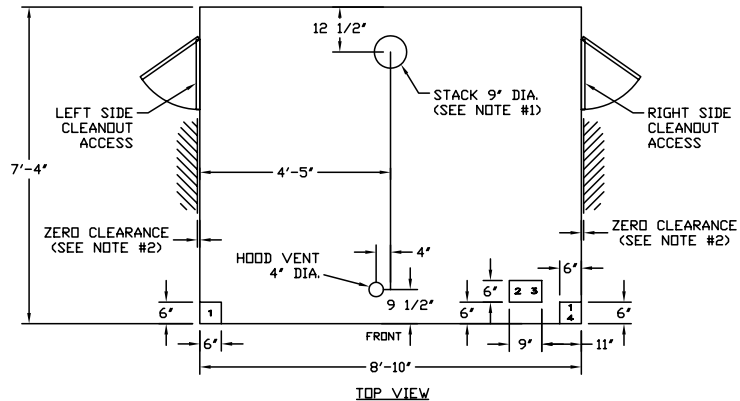

SERVICE CONNECTIONS

- 1 - ELECTRICITY AND GAS MAY BE BROUGHT IN HERE FROM ABOVE OVEN.
- 2 - ELECTRICITY AND GAS MAY BE BROUGHT IN HERE BELOW OVEN. (MAXIMUM PROJECTION OF CONDUIT ABOVE FLOOR = 3').
- 3 - STEAM MAY BE BROUGHT IN HERE FROM BELOW OVEN (IF REQUIRED).
- 4 - STEAM MAY BE BROUGHT IN HERE FROM ABOVE OVEN (IF REQUIRED). ALSO THIS LOCATION FOR CONDENSATE FLOOR DRAIN.

SERVICE LINES

- ONE - 1/2" ELECTRICAL CONDUIT - 115V/1PH/60HZ/20AMP
- ONE - 3/4" GAS LINE - 200,000 BTU
- ONE - ADDITIONAL ELECTRICAL CONDUIT WHEN 220V IS USED FOR ELECTRIC BURNER AND DRIVE.
- ONE - 1" PIPE, STEAM LINE (IF REQUIRED)

NOTES:

#1 - A 9" EXHAUST FLUE MUST BE PROPERLY VENTED TO THE OUTSIDE OF THE BUILDING AND PROVIDE A 0.03-0.05 INCH WATER COLUMN UP DRAFT. A VERTICAL DRAFT DIVERTER OR EQUIVALENT, MUST BE INSTALLED IN ALL NATURALLY VENTED OVENS.

#2 - ZERO CLEARANCE, ONLY IF CLEANOUT IS NOT ON THIS SIDE.

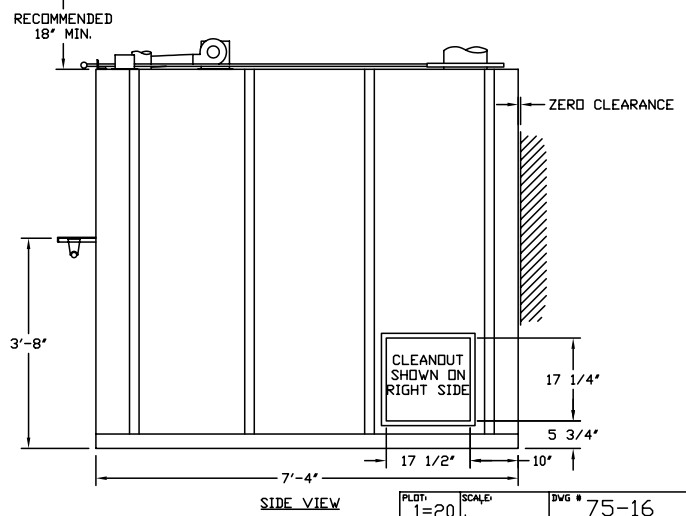
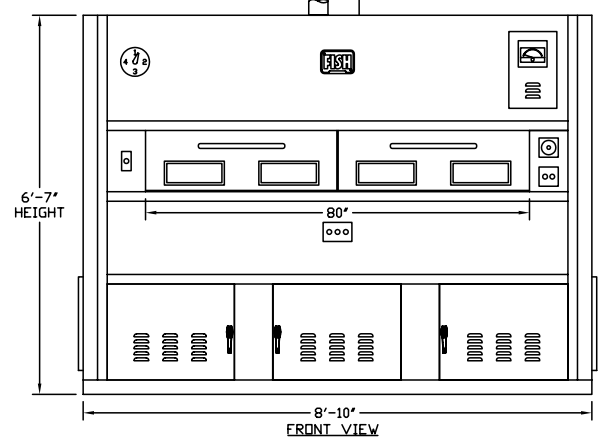

PLOT: SCALE: DWG #
1=20 75-16